

Enabling SNMP for IEEE 802.15.4: A Practical Architecture

Cristian Mihai Vancea and Virgil Dobrota, *Member, IEEE*

Abstract — This paper presents a practical approach for enabling Simple Network Management Protocol for devices using IEEE 802.15.4 standard. This work is focused on providing a system that can be used for management of low-rate wireless personal area network equipment.

Index Terms — embedded systems, network management, Personal Area Network, SNMP

I. INTRODUCTION

IEEE 802.15.4 was developed to address low-cost and low-power design to enable applications in the fields of industrial, agricultural, vehicular, residential, and medical sensors and actuators [1]. This standard deals with low data rate wireless connectivity with fixed, portable, and moving devices with no battery or very limited battery consumption requirements typically operating in the POS (Personal Operating Space) of 10 m. SNMP framework was developed for management of equipment that uses TCP/IP stack. As this is rather a complex stack, it seems that adding SNMP to devices implementing IEEE 802.15.4 standard is not quite suited. In this paper, we present a solution that shows how SNMP can be implemented in PAN coordinators, where the battery consumption is not an issue anymore.

II. SYSTEM'S ARCHITECTURE

The SNMP framework defines four components: the network management station (known as manager), the managed nodes (each containing a processing entity called agent), the network management protocol and the management information (specified by the SMI, the structure of management information, and MIB, the collection of managed objects). There are three versions for SNMP, and we chose to implement SNMPv1 and SNMPv2c [3].

An IEEE 802.15.4-based system contains several components, the device being the basic one. It can be an RFD (Reduced-Function Device) or an FFD (Full-Function Device). Two or more devices within a POS

communicating on the same physical channel constitute a WPAN (Wireless Personal Area network). A network must have at least one FFD, operating as the PAN coordinator. The standard specifies two radio frequency bands that can be used for operation: 868/ 915 MHz ISM band with a maximum bit rate of 40 kbps, and 2450 MHz ISM band with a maximum bit rate of 250 kbps.

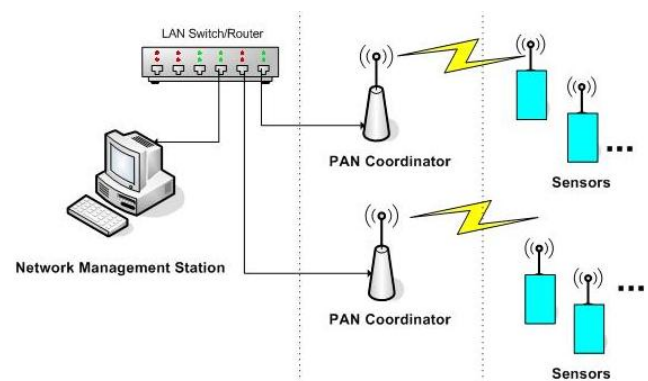

Fig.1 System architecture

The system architecture proposed in Fig.1 consists on a management console developed by our team, called SNMPManager, several PAN coordinators acting as proxy devices and communicating with non-SNMP sensors through IEEE 802.15.4. The main role of a PAN coordinator is to create and maintain a WPAN, to store the information defined by MIB, and communicate with management console using SNMP. The sensor is RFD measuring and storing the temperature in internal memory. The NMS understands data management defined in IEEE 802.15.4 MIB, described later in this paper. SNMP proxies that enable non-SNMP sensors to be managed by a network management framework implement the same MIB.

There are several options for hardware implementation. Our choice was to use microcontrollers in order to minimize the complexity of the equipment. Some microcontrollers have integrated Ethernet interface, or one can be attached to microcontroller using serial interfaces. The first method was selected because it can improve the implementation speed (RAM transfer is generally faster). The same options are available for IEEE 802.15.4 (integrated into controller or not), but there are no microcontrollers that have both interfaces (Ethernet and IEEE 802.15.4). Thus, we decided to use an external circuit for IEEE 802.15.4, connected through a serial interface to MCU. The circuit that is used for radio

Cristian Mihai Vancea is with the Faculty of Electronics, Telecommunications and Information Technologies, Technical University of Cluj Napoca, Romania (phone: 40-264-401264; fax: 40-264-597083; e-mail: Mihai.Vancea@com.utcluj.ro).

Virgil Dobrota is with the Faculty of Electronics, Telecommunications and Information Technologies, Technical University of Cluj Napoca, Romania (phone: 40-264-401226; fax: 40-264-597083; e-mail: Virgil.Dobrota@com.utcluj.ro).

communication is a 2.4 GHz radio module. The proposed hardware architecture for PAN Coordinator is described in Fig. 2.

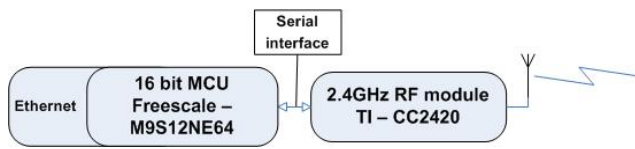

Fig. 2 Hardware architecture for PAN coordinator

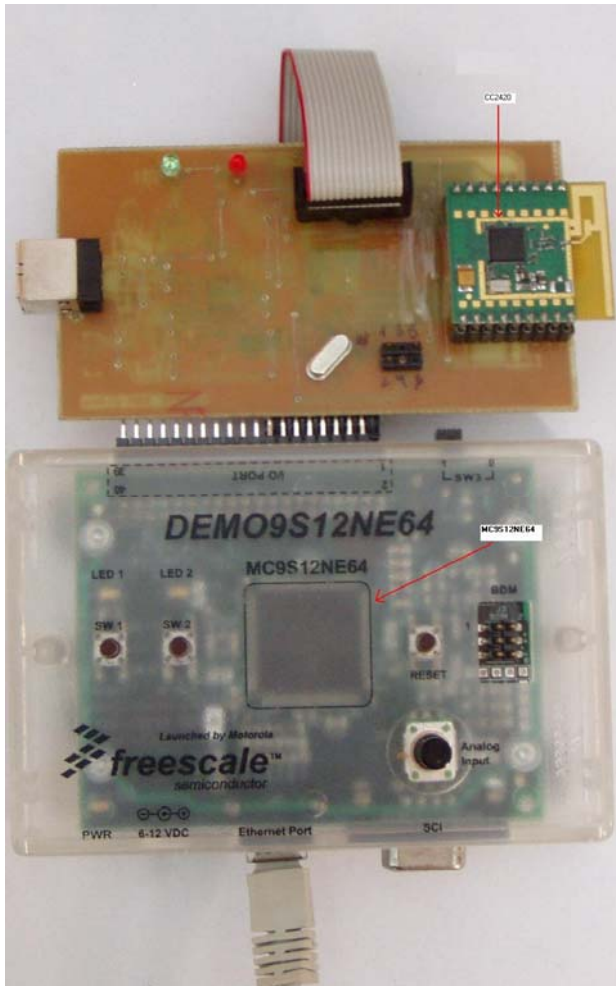

Fig. 3 Picture of one PAN coordinator

The MCU selected is Freescale’s M9S12NE64 and the radio module is based on Texas Instrument’s CC2420 chip (former Chipcon). The MC9S12NE64 belong to a cost-effective, low-end connectivity applications MCU family. This MCU includes among other peripherals, one EMAC (Ethernet Media Access Controller) and one EPHY (Ethernet Physical Transceiver). It contains a 16-bit CPU, running at up to 25 MHz bus speed. The MCU has 64 Kbytes of FLASH EEPROM and 8 Kbytes of RAM. The EPHY supports 10BASE-T or 100BASE-TX applications. Other features are digital adaptive equalization, half-duplex and full-duplex working modes. The EMAC is IEEE 802.3 compliant supporting 10/100 Ethernet operation. Address recognition, match for unicast address, promiscuous mode are some characteristics of EMAC.

The CC2420 is a single-chip 2.4 GHz IEEE 802.15.4 compliant RF transceiver with baseband modem and MAC support. It includes a DSSS (Direct Sequence Spread Spectrum) modem with 2 MChips/s and 250 kbps effective data rate. Further CC2420 can be used for both RFD and FFD operation. It has low current consumption, programmable output power and hardware MAC encryption (AES-128).

Software running on MCU implements protocols needed for SNMP actions (ARP, IP, ICMP, UDP and SNMP itself) and parts of IEEE 802.15.4 stack. The RF module implements the Physical and MAC layers of IEEE 802.15.4. In Fig.4 the implemented protocol stack is described.

Sensors developed for our experiments measure temperature of location where they are placed, and they use the same RF module as PAN coordinators.

Some parts of the protocol stack are implemented in hardware, 802.3u MAC and 100Base-Tx being implemented in MCU, and 802.15.4 PHY being implemented by CC2420 radio module.

Although IEEE 802.15.4 defines the star topology and the peer-to-peer topology, we have chosen the first one. The stack that deals with IEEE 802.15.4 obtains the information from sensors and updates the 802.15.4 MIB. When requested from the management console, or a notification must be generated, SNMP stack read the value from MIB and it sends the data to management console.

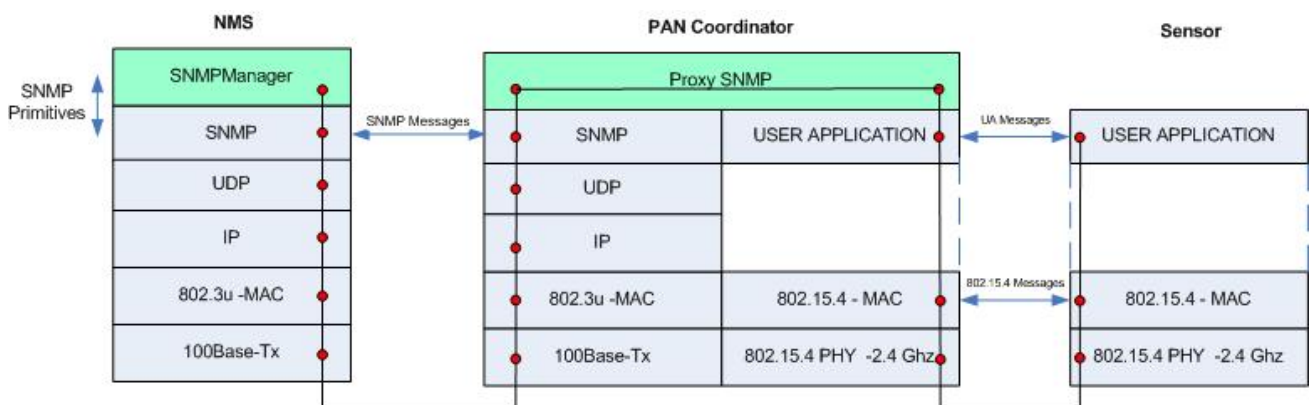

Fig. 4 Protocol stack used by the system

Communication between the two parts of the stack is presented in Fig. 5.

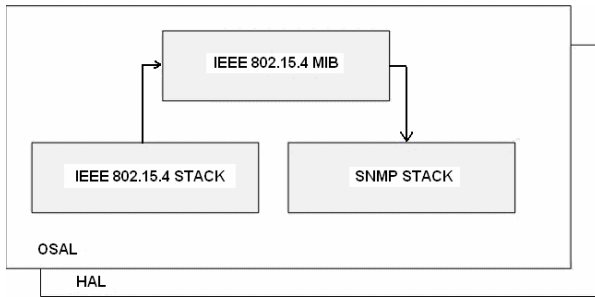

Fig. 5 Software module communication

Operating system running into PAN coordinator is not a Real Time Operating System (RTOS). Each event has an interrupt allocated, which marks the flag associated to the event. Each event is treated by verifying the flags in a continuous loop. Fig. 6 presents the algorithm implemented by the PAN coordinator.

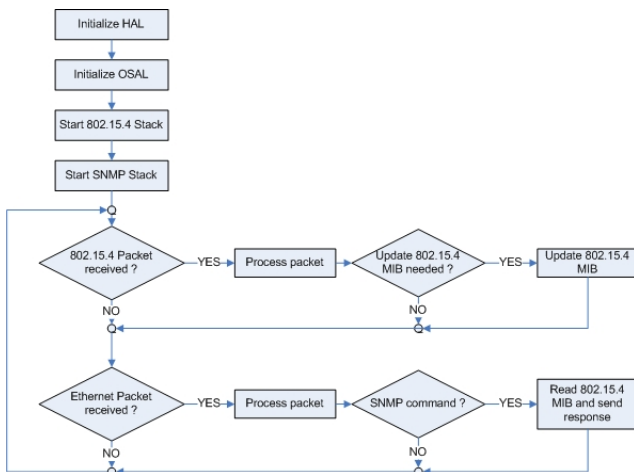

Fig. 6 Algorithm implemented by the PAN coordinator

III. DEFINING THE IEEE 802.15.4 MIB

Management information is viewed as a collection of managed objects, residing in a virtual information store, termed the Management Information Base (MIB). Collections of related objects are defined in MIB modules. These modules were written using a subset of ASN.1 [4]. In order to add SNMP capabilities to an agent, MIB (Management Information Base) must be defined. Our proposal for IEEE 802.15.4 MIB is described in this section. Managed objects are organized into a tree-like hierarchy. Each managed object has an *object identifier* (OID), which uniquely defines a managed object. An object ID is made up of a series of integers based on the nodes in the tree, separated by dots “.”. SMI defines how managed objects are named and specifies their associated data types. Almost all of the numbers assigned are managed by IANA (Internet Assigned Numbers Authority). We proposed a MIB structure that holds information for physical and data link layer from 802.15.4. It was written using SMIV2 and it has five sections: Physical Layer; Data Link Layer; system description; trap

notifications and associated devices [2]. We selected to put the MIB under experimental branch, assigning 26840 as starting point, randomly chosen among available OIDs not yet allocated by IANA. The *experimental* branch is reserved for testing and research purposes. The proposed MIB structure is described in Fig. 7 and Table 1.

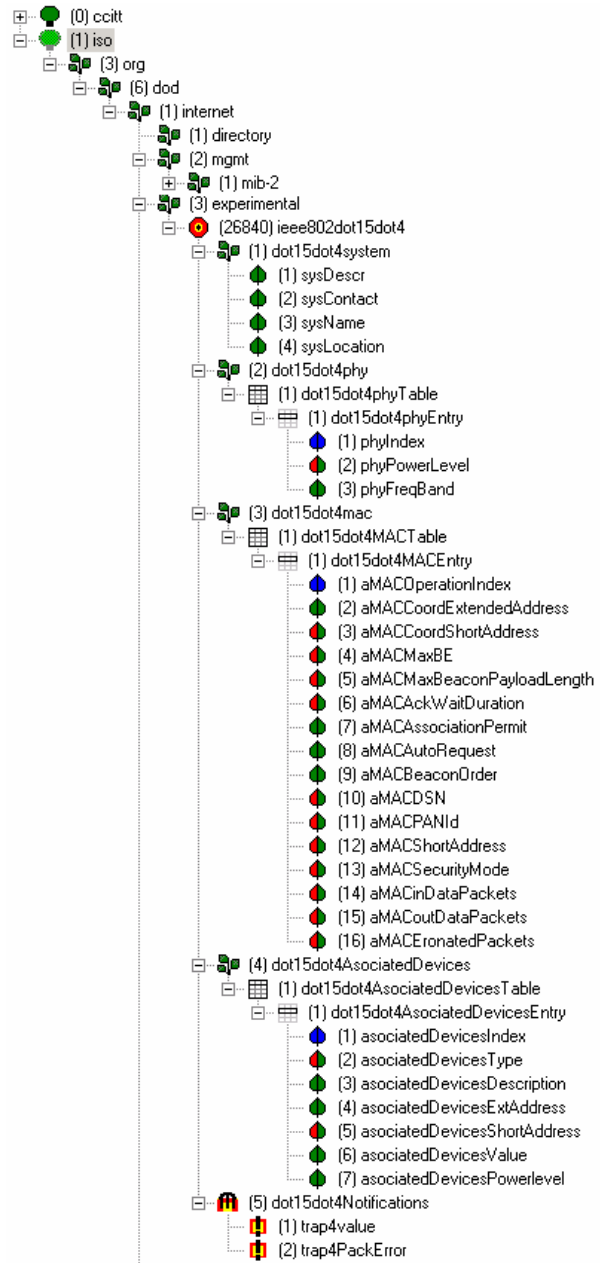

Fig. 7 Proposed MIB structure

Table 1: Parameters from MIB

Section	Parameter/ OID	Description
dot15dot4system	sysDescr 1.3.6.1.3.26840.1.1	A textual description of the entity
	sysContact 1.3.6.1.3.26840.1.2	The textual identification of the contact person for this managed node
dot15dot4phy	phyFreqBand 1.3.6.1.3.26840.2.1.1.3	Frequency band used at physical layer
	phyPowerLevel 1.3.6.1.3.26840.2.1.1.2	Power level at physical interface
dot15dot4mac	aMACPANId 1.3.6.1.3.26840.3.1.1.11	The 16-bit identifier of the PAN on which the device is operating
	aMACinDataPackets 1.3.6.1.3.26840.3.1.1.14	Total number of packets received by coordinator
dot15dot4AssociatedDevices	associatedDevicesValue 1.3.6.1.3.26840.4.1.1.6	Measured value obtained from device
	associatedDevicesShortAddress 1.3.6.1.3.26840.4.1.1.5	Short physical address of the device associated
dot15dot4Notifications	trap4value 1.3.6.1.3.26840.5.1	Notification for sensors values exceeding the threshold
	trap4PackError 1.3.6.1.3.26840.5.2	Notification for number of packets with error exceeding the threshold

IV. EXPERIMENTAL RESULTS

After hardware equipment and integration of the MIB in management console and PAN coordinators were finished, a series of experiments were conducted, in order to validate the system. We used all equipment described above (proxy devices, MIB, sensors) and SNMPManager. Fig. 8 presents the equipment’s placement.

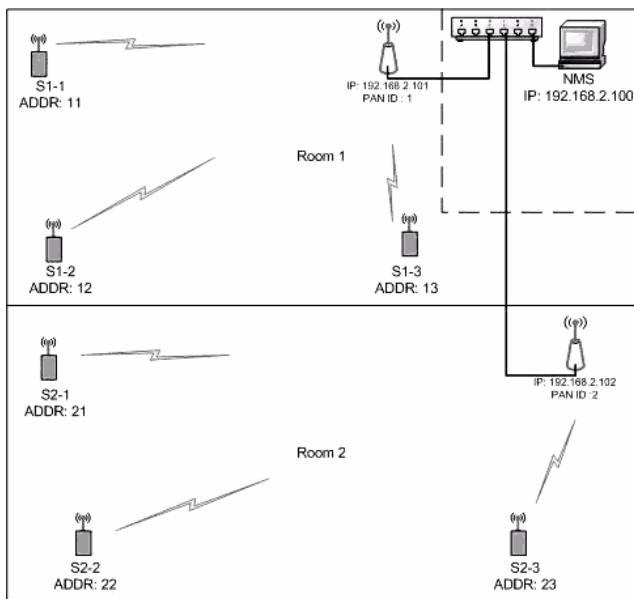

Fig. 8 Equipment’s placement

The first experiment (see Fig. 9) consisted on generating traps when the number of frames with errors increased above a threshold. This number was influenced by the presence of other devices operating in the same ISM band. We placed a number of six sensors in two different rooms (S1-1, S1-2, S1-3 in room 1, forming a WPAN, and S2-1, S2-2, S2-3 in room 2, forming another WPAN).

In order to intentionally produce frames with errors, a number of devices using the same radio frequency band

were placed (i.e. microwave oven, 802.11 and Bluetooth devices).

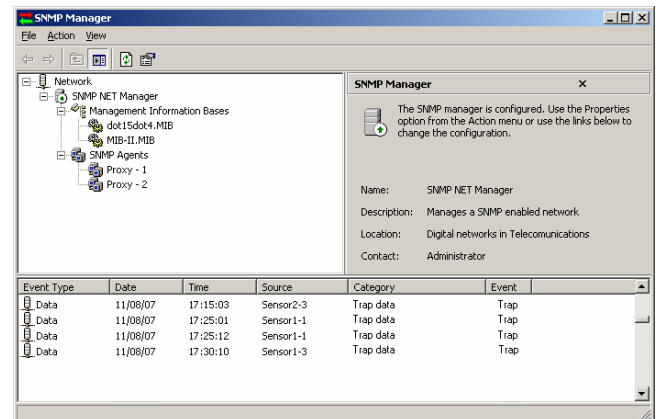

Fig. 9 SNMPManager receiving trap messages on NMS

The second experiment (see Fig. 10) consists on monitoring the temperature of each sensor. The manager pools periodically the SNMP proxies for retrieving temperature from each sensor.

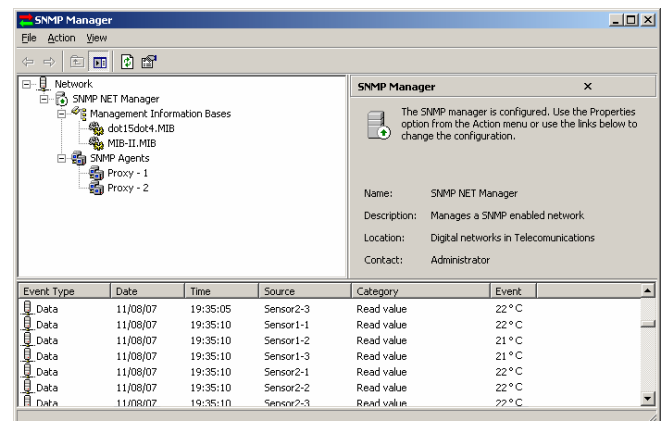

Fig. 10 SNMPManager monitoring temperature on NMS

V. CONCLUSIONS AND FUTURE WORK

The system architecture proposed in this paper can be used to monitor environmental information (temperature, humidity etc.). By installing sensors in sensible locations, network administrators can monitor these parameters using the same management system as for the networking devices. Experiments carried out by us show that integrating IEEE 802.15.4 sensors into a centralized management system represents a feasible solution. The main purpose for this study was to create a hardware and software system that can be easily integrated into an already running management system.

As future work, we will extend the current MIB to add other mandatory information. On top of the implemented IEEE 802.15.4 layers a new MIB for ZigBee (Layer 3 and above) will be realized. Additional notifications must be defined in order to have more unsolicited information. For improving security of data transferred, SNMPv3 will be implemented into proxies. At this moment, only Get operations are permitted, due to lack of security offered by SNMPv1 and SNMPv2. In addition, SNMP must be implemented also into wireless sensors, but there are many open issues [5]. For instance, integration of SNMP into each sensor supposes that IP and UDP are already implemented, but this needs some resources that usually are not available. Other problems described in [6] are the following: IP connectivity, topologies, limited configuration and management, security. The proposed solution is IPv6 on top of IEEE 802.15.4, whilst the management protocol could be SNMP, with possible adaptations. To improve the performances, a real-time operating system should be implemented by coordinators, because it offers minimal interrupt latency and minimal thread switching latency.

REFERENCES

- [1] IEEE Std.802.15.4, IEEE Standard for Wireless Medium Access Control (MAC) and Physical Layer (PHY) Specifications for Low-Rate Wireless Personal Area Networks (LR-WPANs), 2003.
- [2] K. McCloghrie, D. Perkins, J. Schoenwaelder - Structure of Management Information Version 2 (SMIv2), RFC2578. April 1999.
- [3] William Stallings, "SNMP, SNMPv2, SNMPv3, and RMON1 and 2 Third Edition," Addison Wesley New York, 1998
- [4] Information processing systems - Open Systems Interconnection - Specification of Abstract Syntax Notation One (ASN.1), International Organization for Standardization. International Standard 8824, (December, 1987).
- [5] 6LoWPAN: Overview, Assumptions, Problem Statement and Goals, Nandakishore Kushalnagar, (draft-ietf-6lowpan-problem-07.txt), February 2007
- [6] 6LoWPAN: Overview, Assumptions, Problem Statement and Goals," Nandakishore Kushalnagar, (draft-ietf-6lowpan-problem-07.txt), April 2007